

M10

EXPERIMENTAL INVESTIGATION OF BORDA-CARNOT AND DIFFUSER GEOMETRY

1. The aim and practical aspects of the measurement

The aim of the measurement is to investigate the flow field in the Borda-Carnot and diffuser hydraulic elements by flow visualisation techniques, as well as taking the pressure distribution measurements along the channel wall. The connection between the wall pressure distribution and the flow pattern in the channel needs to be determined following the measurement. Another objective of the measurement is to determine the efficiency of the Borda-Carnot and diffuser elements.

Pipelines and canals are frequently used in the transportation process of liquids and gases. In such cases it often happens that the cross section of the tubes or channels have to be increased in the direction of the flow. Increase in the cross section of the channel results in the decrease of the flow velocity, assuming that the fluid is incompressible and it fills the available volume of the channel. This is known as the law of mass conservation. From a dynamical viewpoint, the deceleration of the fluid particles in a diffuser is caused by the pressure gradient pointing in the streamwise direction. Therefore the pressure in front of a fluid particle is always higher than behind it, meaning that the pressure force is acting in the opposite direction than the velocity vector is pointing. Thus the fluid is slowing down in the diffuser. In a frictionless case the deceleration of the fluid is trouble free. However in the presence of friction, a boundary layer forms along the duct wall, the thickening of which causes flow separation. The boundary layer separation can be explained by the examination of the energetic conditions of the flow in a diffuser. The work which is required to move a fluid particle from a place of lower pressure to

a place of higher pressure is acquired from the kinetic energy of the particle, and results in the slowing down of the fluid. For inviscid flow this process can be realized in the entire cross-section of the channel without any difficulty. In the case of viscous flow, the fluid particles in the middle of the channel decelerate properly. However, close to the wall in the boundary layer, the kinetic energy of the fluid particles is small and thus they decelerate dramatically or even stop and move backwards as a result of the pressure gradient. The flow separation is indicated by the boundary layer thickening and appearance of recirculation and separation bubbles (See [1] for more information).

The thickening of the boundary layer and the forming of separation bubbles results in the increase of dissipative losses. This increases the losses in the pipeline system, which leads to a higher hydraulic resistance. Therefore more power needs to be fed into the system in order to move the fluid. Besides the fluid losses, the unstable boundary layer separation can lead to structural vibrations and noise emission. Furthermore, the separated flow in a pipeline can unfavourably affect the machine and its flow phenomena, which it is connected to. (e.g. If the flow is fluctuating in the air supply system of a furnace burner due to an unstable flow separation then, the flame and the heat source will also be fluctuating.) Hence in hydraulic systems like pipelines and canals, it is a general aspect to avoid the separation of the boundary layer. In approaching this problem, there are two objectives. The first is to familiarize ourselves with the features of optimally designed cross sectional growth, from a purely aerodynamic viewpoint. At the same time, it should be understood that hydraulically optimal diffuser geometry can not be realised in many practical situations. While on the other hand we must be acquainted with what the effect of the manufacturing and operational tradeoffs are on the flow. This measurement gives us an opportunity to become familiar with these practical questions under laboratory conditions.

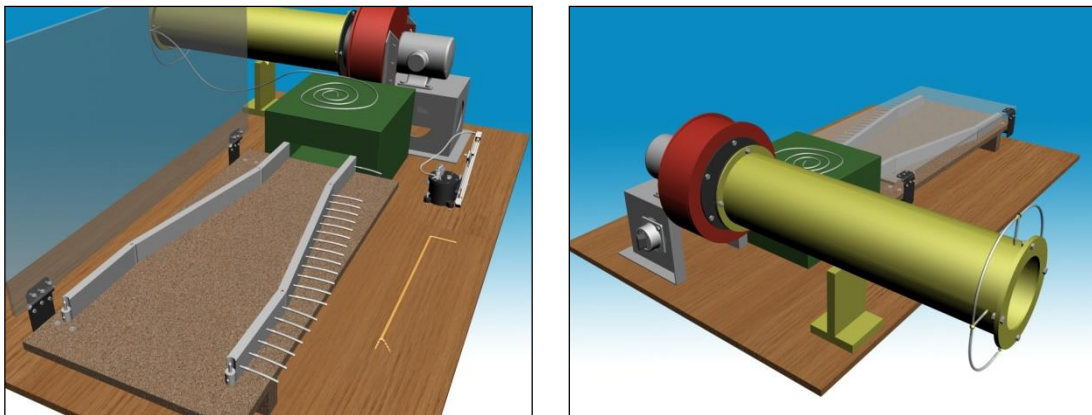

Figure 1: 3D schematic figure of the measurement

2. Description of the measurement facility

The measurement facility, which can be used to investigate plane channel flows, contains two main parts. The first part is a miniature wind tunnel, which provides the uniform inlet velocity profile and the second part, which is the adjustable measuring section. The complete measurement device can be seen in Fig. 1. The different sections of the facility are as follows:

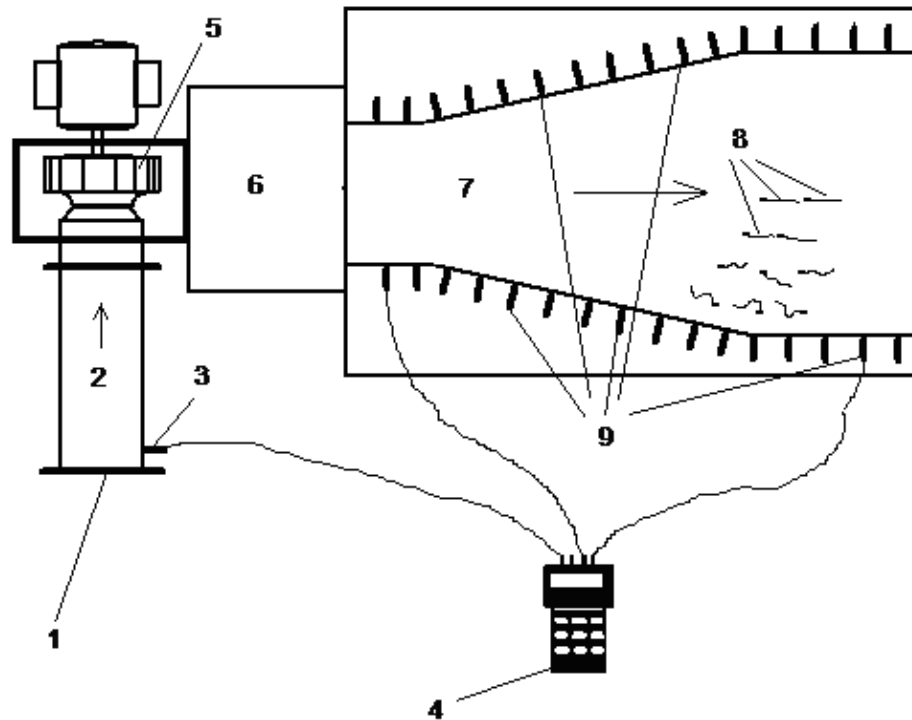

Figure 2: 2D schematic figure of the measurement

1. Inlet orifice plate for measuring the flow rate.
2. The air intake tube.
3. Pressure measurement point, which consists of a small pressure tap at the beginning of the suction tube directly downstream of the inlet orifice plate. For the pressure measurement, the tap is connected to the proper tap of the pressure transducer (in this case that which is denoted by “-”) with a thin rubber tube. The volume flow rate can be calculated from the measured pressure.
4. Two-channel digital manometer.
5. The air is circulated by an electrically driven radial fan.
6. Flow straightener, which provides a uniform outlet velocity profile. In this chamber the fluid goes through wire gauze and discharges into the measurement section through a confuser. The role of the wire gauze and the confuser is to straighten the nonuniform velocity profile coming from the fan.
7. The measurement section provides us with the possibility to assemble different channel geometries for investigation. The almost uniform flow from the straightener is led directly into the adjustable measurement section. The measurement section is bounded on the bottom by a cork covered base plate (the flow visualisation flags (8) can be stuck into the cork). The top of the channel consists of a transparent plexiglas plate, which can be opened. The sides are made up of four sections with different lengths. An arbitrary number of diffuser geometries can be formed by placing the side elements between the base and the top plate, fitting the first element to the outlet slot of the flow straightener. The flow pattern is visualized by the small flags, which turn into the flow direction. They can be observed through the transparent top plate.

(Note: The base and the top plates form parallel planes, and in every cross section of the channel the sidewalls are perpendicular to them. Therefore, as a first approximation, by neglecting the displacement effect of the boundary layer it can be assumed that the fluid particles do not deflect perpendicularly to the bottom and top boundaries. Generally speaking, the flow variables in this direction are changing with a much smaller rate than along the other two dimensions of the measurement section. These are the characteristics of the set-up, which give us the opportunity to investigate relatively simple two dimensional flows in this facility.

8. Flow visualisation flags.
9. Pressure taps, where the pressure along the wall of the channel can be measured.

Beside the previously described measuring facility, other auxiliary devices are also needed for the measurement (e.g. barometer, thermometer, tape measure etc.) These are also provided in the laboratory.

3. Detailed description of the measurement task, basic tests and post-processing aspects

The extensive examination of the topics outlined in Section 1. would require a long amount of time. Within the confines of this laboratory measurement, three types of basic investigations have to be completed:

- A. Investigation of symmetrical diffusers with different cross section ratios and different setting angles.
- B. Investigation of asymmetric diffusers with different cross section ratios and different setting angles.
- C. Investigation of symmetric and asymmetric Borda-Carnot transitions with constant cross section ratios.

The specific measurement tasks will be assigned by the measurement instructor.
The following experiments are proposed.

3.1. Investigation of the flow pattern in the channel using a flow visualisation technique

The first step is to build the required expanding channel section by placing the proper side wall elements onto the base plate. Following this, the flow visualisation flags need to be stuck into the base plate in the free-stream flow of the channel. The visualisation flags are pins with a 30-35 mm length soft and fluffy thread mounted to the upper part of the pins. Taking into consideration the nature of the process, the flags need to be placed with 20-90 mm spacing. It is evident that the flags should be placed densely in the places where the flow changes significantly within a short distance and sparsely where the flow is undisturbed. It is advisable to place the threads on the pins approximately at the mean of the channel height. After the flow is started the flags turn into the local flow direction. If the flags are properly placed, the flow pattern in the channel is visualized by the many small threads. In order to document the observations, a freehand sketch or a photograph should be made of the flags. The sketch should focus on the sudden direction changes and separations which appear in the flow. It is practical to separately denote the contours of each observed separation bubble on the drawings.

3.2. Measurement of the sidewall pressure distribution and determination of the inlet and outlet velocity profile in the channel

Beside the velocity field, another important characteristic property which is present in the fluid flow is the pressure distribution. The pressure changes are in correlation with the changes in the flow pattern. Many velocity and flow rate measurement devices apply this observation (e.g. Pitot-static-probe, Venturi tube). In the present experimental exercise the sidewall pressure distribution needs to be determined and observations between the pressure distribution and flow pattern should be given. The pressure along the channel wall can be measured by a digital manometer using the pressure taps placed on the sidewalls of the channel. With a rubber tube one tap of the manometer is to be connected to that sidewall tap, where the pressure is to be

measured. The other tap of the manometer is to be left unconnected. Thus the value to be read from the display is the relative overpressure with respect to the atmospheric pressure. In this way, measuring only one pressure at a time, we can map the wall pressure distribution on both sides of the channel. The pressure values right before and after the cross-section change are important base values for the post-processing. Therefore special attention needs to be devoted to determining these values. It is advisable to draw a chart with the measurement results of sidewall pressure values. By comparing the pressure distribution chart and the flow pattern sketch the connection between them can be found, which should be documented in detail.

At the inlet section of the channel a Pitot-static-probe velocity measurement should be done in order to check the uniformity of the inlet velocity profile and to calculate the approximate value of the average velocity and compare it to the value computed from the inlet orifice plate. The average velocity should be determined based on the rules of the point to point Prandtl-probe measurement. In the inlet section the measurement points should be evenly distributed with 7-15 mm of spacing. This needs to be repeated at the outlet section of the channel for every configuration, with a spacing of 15-30 mm. Results should be presented in a table and a chart along with the average velocity values computed from the inlet orifice plate measurements.

3.3. Determination of the diffuser efficiency for the Borda-Carnot and the diffuser elements

The experimental methods described in subsections 3.1 and 3.2 can be used in a detailed analysis of the expanding channels. In the everyday engineering practice it is usually unnecessary to use such a detailed description. In such cases it is beneficial to use only one quality indicator for the expanding channel geometries called the diffuser efficiency. Though this indicator does not define the loss sources, for the design procedure of a pipeline system, where one dimensional models are usually used and the detailed information on the flow is not needed, this parameter is enough to calculate the pressure loss of the element.

The diffuser efficiency is the ratio of the real and ideal pressure rise occurring in the expanding channel:

$$\eta_d = \frac{(p_{out} - p_{in})_{real}}{(p_{out} - p_{in})_{ideal}} \quad (1)$$

where: η_d [-] is the diffuser efficiency of the expanding channel.

p_{out} [Pa] is the pressure at the outlet section of the diffuser.

p_{in} [Pa] is the pressure at the inlet section of the diffuser.

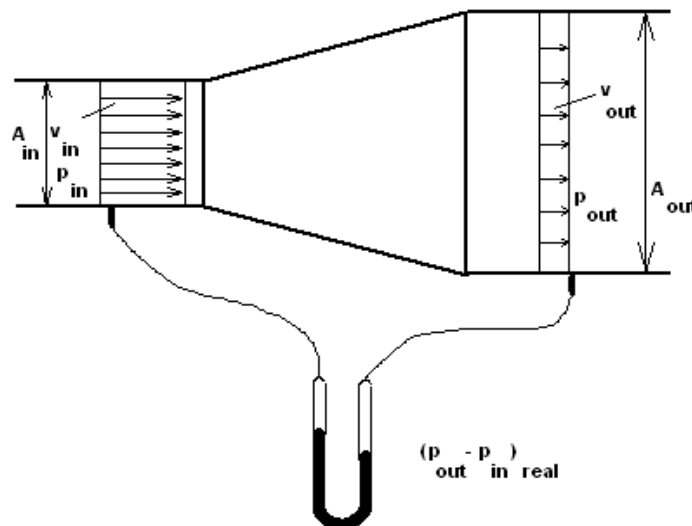

Figure 3: Measurement procedure

$$\eta_d = \frac{(p_{out} - p_{in})_{real}}{\frac{\rho_{air}}{2}(v_{in}^2 - v_{out}^2)} \quad (2)$$

The determination of the diffuser efficiency can be summarized as follows:

- On the assembled measurement facility connect the pressure taps at the inlet and outlet section of the expanding channel to the links of the manometer. (The “-” tap of the manometer is connected to the inlet section and the “+” tap is connected to the outlet section) The real pressure difference on the channel can be read from the display.

- The density of the air can be computed from the barometric pressure and from the temperature of the laboratory. A barometer and a thermometer are located in the laboratory for this purpose.

$$\rho_{air} = \frac{p_0}{RT_0} \quad (3)$$

Where:

ρ_{air} [kg/m ³]	fluid density of the air.
p_0 [Pa]	barometric pressure.
$R= 287$ [J/kgK]	specific gas constant of the air
T_0 [K]	temperature of the laboratory

(Note: Taking into consideration the operating range of the measurement facility, it can be assumed that the flow in the measurement set-up is incompressible)

- v_{out} and v_{in} are the average velocities in the inlet and outlet sections of the expanding channel. Knowing the volume flow rate through the facility q_v and the area of the inlet A_{in} and outlet A_{out} cross sections of the expanding channel the inlet and outlet velocities can be computed as follows:

$$v_{out} = \frac{q_v}{A_{out}} \quad (4) \quad \text{and,} \quad v_{in} = \frac{q_v}{A_{in}} \quad (5)$$

The volume flow rate q_v can be measured with the inlet orifice plate mounted at the beginning of the suction tube. It is assumed that the fan intake occurs through the orifice and discharges into the ambient fluid only at the channel exit. This means that the sealing in system is perfect and since the density is constant, the volume flow rate does not change in the device.

The volume flow rate can be determined by the inlet orifice plate as follows. The relative pressure as compared to the atmospheric pressure Δp_{op} is measured at the tap following directly after the orifice plate at the beginning of the suction tube. The volume flow rate q_v can be computed from Δp_{op} with the following expression:

$$q_v = \alpha \varepsilon \frac{d^2 \Pi}{4} \sqrt{\frac{2 \Delta p_{op}}{\rho_{air}}} \quad (6)$$

Where: q_v [m³/s] is the volume flow rate through the orifice

α [-] is the contraction ratio, which depends on the area ratio of the orifice and the tube and on the Reynolds number. The value of α is determined from

experimental investigations and it has been summarized in handbooks. In this measurement the contraction ratio is approximately 0.6.

ε [-] is the expansion number, which is assumed to be 1 in the circumstance of small pressure variation through the system, such as in this measurement.

d [m] is the diameter of the orifice plate.

Δp_{op} [Pa] is the pressure loss on the orifice plate.

ρ_{air} [kg/m^3] is the density of the fluid.

Having the values of ρ_{air} , v_{out} and v_{in} , the ideal pressure increase, which is the denominator of expression (2), can be determined. Then the diffuser efficiency is computable.

3.4. A laboratory report on the experimental investigations should be prepared.

3.4.1. The laboratory report must contain the following charts:

- Velocity profiles $v_x(y)$ at the inlet and outlet sections of all measurement configurations. Here x is the flow direction.
- $\Delta p_i = p_0 - p_{st,i}(x)$ The static pressure distribution along the walls of the measuring section.
- Flow pattern sketches in the vicinity of the wall, which were visualised with the threads.
- Borda-Carnot loss calculations for the measurements.
- Diffuser efficiency as a function of the investigated parameters.

3.4.2. The measurement error calculation needs to be done as described below, for the following variables:

The diffuser efficiency:

the absolute error:

the relative error:

$$\eta_d = \frac{(p_{out} - p_{in})_{real}}{\frac{\rho_{air}}{2} \left(\left(\frac{q_v}{A_{in}} \right)^2 - \left(\frac{q_v}{A_{out}} \right)^2 \right)} \quad (7)$$

$$\delta \eta_{diff.} = \sqrt{\sum_{i=1}^n \left(\delta X_i \frac{\partial \eta_{diff.}}{\partial X_i} \right)^2} \quad (8)$$

$$\frac{\delta \eta_{diff.}}{\eta_{diff.}} = ? \quad (9)$$

Where X_i is the measured quantity: and its absolute error is:

$X_1 = p_0$	$\delta p_0 = 100 \text{ Pa}$
$X_2 = T_0$	$\delta T_0 = 1 \text{ K}$
$X_3 = \Delta p$	$\delta p = 2 \text{ Pa}$

If the volume flow rate presented as follows: $q_v = \alpha \varepsilon \frac{d^2 \Pi}{4} \sqrt{\frac{2 \Delta p_{op}}{\rho_{air}}}$, the density will drop out, therefore the measurement error comes from the pressure measurement only. The diffuser efficiency's absolute error comes from the measurement error of $(p_{out} - p_{in})_{real}$ and Δp_{op} .

Remember that during the labs:

- Before turning any measurement device on, or in general during the lab, make sure that safe working conditions are ensured. The other participants have to be warned of the starting of the machines and of any changes that could endanger the members of the lab group.
- The atmospheric pressure and room temperature should be recorded before and after every measurement..
- The measurement units and other important factors (e.g. data sampling frequency, date of calibration) of every recorded value of the applied measurement devices should be recorded.
- Type and construction number of the applied measuring instrument should be included in the final report.
- Checking and harmonizing of the units of the recorded values with those used in further calculations.
- Manometers should be calibrated if necessary.
- The measurement ports of the pressure meter should be carefully connected to the correct pressure ports of the instrument.
- If inlet or outlet tubes are to be assembled with fans, connections should be airtight as escaping/entering air can significantly modify the measurement results.
- The students should consult with their instructor before submitting the report.

References

[1] Joseph H. Spurk & Nuri Aksel, Fluid Mechanics, 2008. Chapter 9.1.4 Application to Flows with Variable Cross-Section

Possible questions

- ❖ What is the aim of the measurement? Why is it important?
- ❖ What are the steps of the measurement?
- ❖ What are the basic investigations?
- ❖ How can be calculated the following quantities: density, volume flow rate, diffuser efficiency?
- ❖ Describe the pressure distribution inside the diffuser!